



STRETCH OUT DISCUSSION

Early Period Stretch Glass Candlesticks

Will be the topic of our *Stretch Out* Discussion on
Thursday, 10/11/18

at 8 pm Eastern, 7 Central, 6 Mountain & 5 Pacific Time.

All are welcome to join in by calling **415-464-6800**,
followed by **ID: 04211974#**

Tall “Trumpet”: Who made them?

1. Cup Rim: Central, rounded & no mold seam; Diamond. Angular & mold seam
2. Second holder ring: Central, straight holder & cove in; Diamond, rounded out
3. Base: Central, rounded & no seam; Diamond, straight sided & mold seam

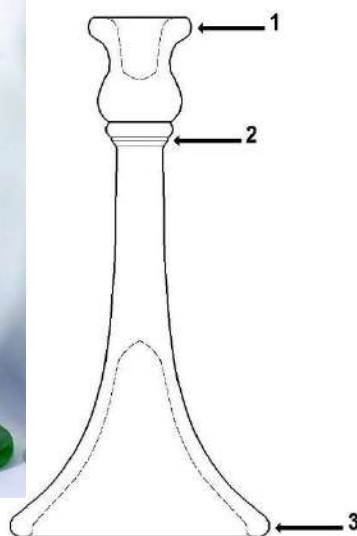

Central

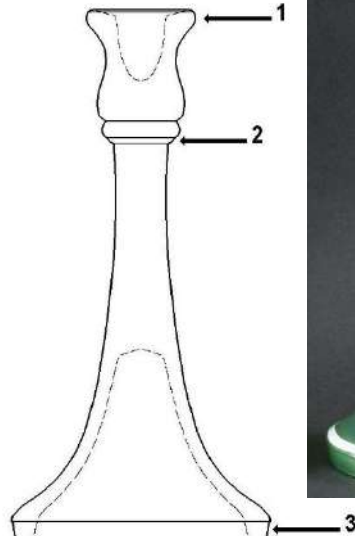

Diamond



Short "Trumpet": Who made them?

1. Cup Height: Northwood, short; Central, tall; Vineland, medium
2. Holder rings: 2 rings = Northwood & Central; 3 rings = Vineland

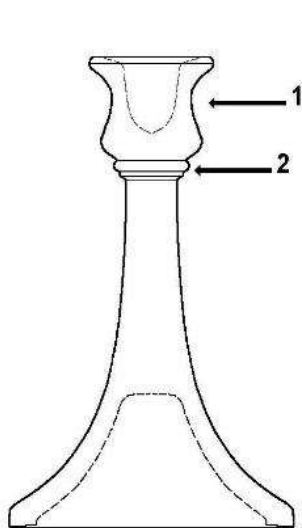

Northwood

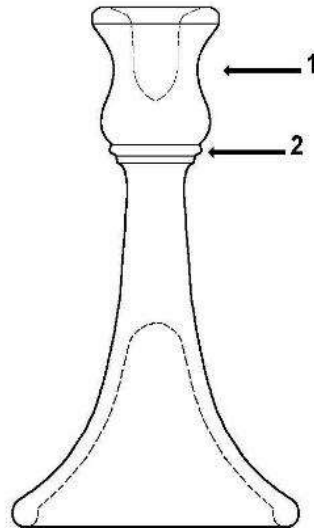

Central

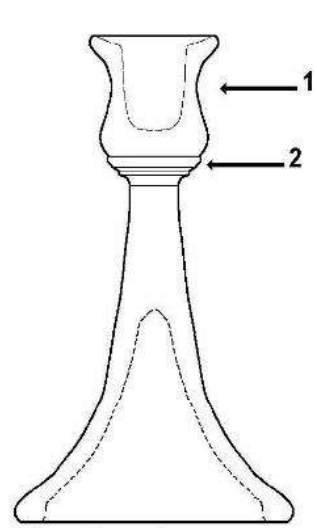

Vineland



“Colonial”: Who made them?

1. Mold seams: 2 seams = Fenton, Northwood; 3 seams = Vineland
2. Stem finial: ball = Northwood, sloped = Fenton, Vineland

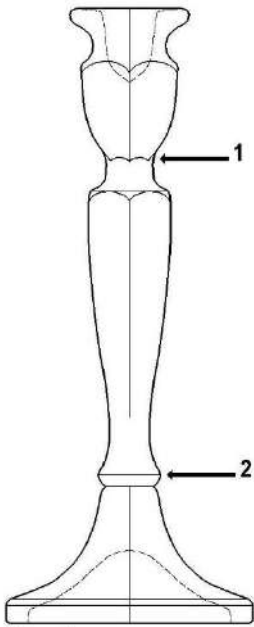

Fenton

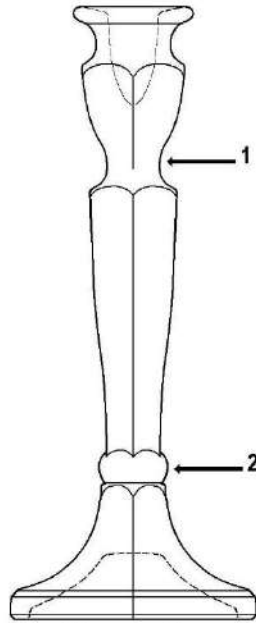

Northwood

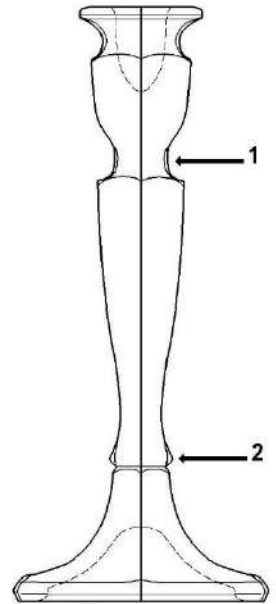

Vineland



“Spindle”: Who made them?

1. Middle spindle wide section: Diamond & Imperial, at bottom; Vineland, at top
2. Top & bottom rings: Diamond’s & Vineland’s are thick; Imperials are thin

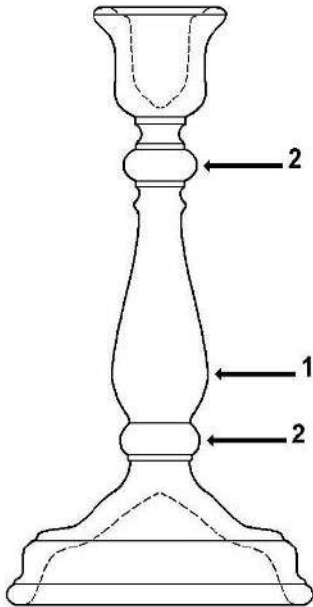

Diamond

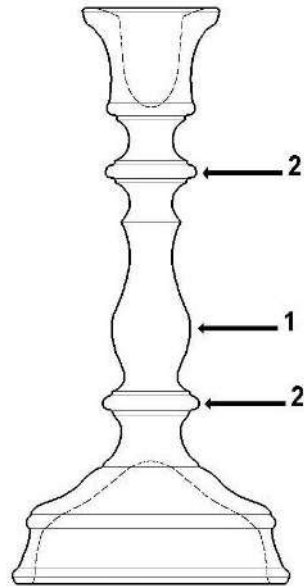

Imperial

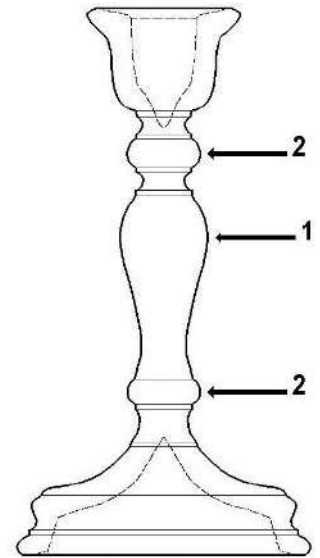

Vineland











